



LR-500-Portable Programmable Display FM Receiver
LR-400-Portable Display FM Receiver

Don't miss a single sound.





Dear Valued Customer,

Thank you for choosing Listen! All of us at Listen are dedicated to providing you with the highest quality products available. We take great pride in their outstanding performance because we care that you are completely satisfied. That's why we independently certify them to the highest quality standards and back them with a limited lifetime guarantee. We stand ready to answer any questions you might have during installation or in the operation of our products. Should you experience any problems whatsoever with your Listen products, we are ready to help you in any way we can with prompt, efficient customer care. Because at Listen, it's all about you! And should you have any comments on how we might improve our products or our service, we're here to listen.

Here's how to reach us:

+1.801.233.8992
+1.800.330.0891 North America
+1.801.233.8995 fax
support@listentech.com
www.listentech.com

Thank you and enjoy your listening experience!

Best regards,
Russell Gentner and the Listen Team

- In the few instances where repairs were needed, 99% of all clients indicated that they were happy with repair turn-around-times and 85% of the time, clients were without their product for less than 10 days!
- Overall client satisfaction of working with Listen was rated 4.8 out of 5.
- "Please continue with your excellent attitude toward customer satisfaction. You guys are great!"
- "I've never had such good service from any company. Keep up the good work!"
- "You stand behind your product wonderfully."

Receivers Table of Contents

<i>LR-500 Manual</i>	3
LR-500 Table of Contents	5
<i>LR-400 Manual</i>	19
LR-400 Table of Contents	21

Supplementary Information	32
Channel Selection	32
Listen SQ™	33
RF Reception Maximization Strategies	34
150 MHz Frequency Compatibility Table	35
Troubleshooting	36
Warranty	38
Contacting Listen	38
Optional Accessories	39



LR-500-Portable Programmable Display FM Receiver

Don't miss a single sound.

LR-500 Table of Contents

Package Contents	6
Architectural Specifications	7
Specifications	7
Quick Reference	8
Setup Instructions	9
Operation Instructions	11
Programming Instructions	13
Squelch Information	14
Squelch Programming	14
Charging Batteries	15
Wall Transformer Operation	16

LR-500 Package Contents

LR-500 Contents

- LR-500 Portable Programmable Display FM Receiver (150 MHz)

Listen Part Number

- LR-500-150 (150 MHz)



LR-500 Specifications

Architectural Specifications

The FM receiver shall be capable of receiving on 32 channels. The receiver shall have a SNR of 80 dB or greater. The receiver shall be programmable to electronically lock out unneeded channels. The receiver shall be capable of seeking channels locked on an active channel. The device shall have a squelch. The unit shall have an audio frequency response of 50 Hz to 15 kHz (± 3 dB). The device shall incorporate a stereo headset jack that allows the user to plug in either a mono or stereo headset and listen to audio normally. The device shall incorporate an LCD display. The receiver shall incorporate automatic battery charging circuitry. The device shall be able to use of two (2) alkaline or NiMH batteries. The Listen LR-500-150 is specified.

Specifications*		
Audio	RF Frequency Range	150.8000 MHz - 152.3500 MHz
	Number of Channels	6 wide band, 26 narrow band
	Sensitivity	.6uV typical, 1 uV maximum for 12 dB sinad
	Frequency Accuracy	$\pm .005\%$ stability 32 to 122 °F (0 to 50 °C)
	Antenna	Uses earphone cable
	Squelch	Programmable in 20 steps, automatic on loss of RF signal
	System Frequency Response	50 Hz - 15 kHz (± 3 dB)
	System Signal to Noise Ratio	SQ enabled 80 dB, SQ disabled 60 dB
	System Distortion	<2% total harmonic distortion (THD) at 80% deviation
	Output	3.5 mm (0.14 in.) connectors, unbalanced, 0 dBu nominal output level, 16 mW maximum, impedance 32 ohm
Controls & Indicators	User Controls	Channel up/down, SEEK, volume
	Set-up Controls (Battery Compartment)	Alkaline/NiMH batteries, SQ enable/disable
	Programming	Channel lock, squelch, channel lock out
	LED	Red, illuminated when unit is on, flashes when batteries are low or to indicate charging, flashes when locked and SEEK is pushed
	Display	Channel designation, battery level, battery charging, RF signal strength, programming and channel lock
Power	Battery Type	Two (2) AA batteries, alkaline or NiMH
	Battery Life (Listen Batteries)	30 hours alkaline (LA-361), 15 hours NiMH rechargeable (LA-362)
	Battery Charging (NiMH only)	Fully automatic, 13 hours
	Power Supply	I/P 120 VAC; O/P 7.5 VDC 250 mA, drop in contact points for use with charging cases, power supply not included (LA-208)
	Power Supply Connector	0.09 in. (2.3 mm) OD by 0.7 mm ID, barrel type connector 7.5 VDC, center positive <250 mA, drop in contact points for use with Listen charging cases
	Power Supply Compliance	RoHS, WEEE, UL, PSE, CE, CUL, TUV, CB
Physical	Dimensions (H x W x D)	4.25 x 2.75 x 1.50 in. (10.8 x 7.0 x 3.8 cm)
	Color	Dark Grey with white silk screening
	Unit Weight	3.9 oz (111 g)
	Unit Weight with batteries	5.8 oz (164 g)
	Shipping Weight	6.1 oz (173 g)
	Door	Manually Lockable (on sides). Up, down, and power buttons through door.
Environmental	Temperature-Operation	14 to 104 °F (-10 to 40 °C)
	Temperature-Storage	(-)4 to 122 °F (-20 to 50 °C)
	Humidity	0 to 95% relative humidity, non-condensing

*Specifications are subject to change without notification

LR-500 Quick Reference

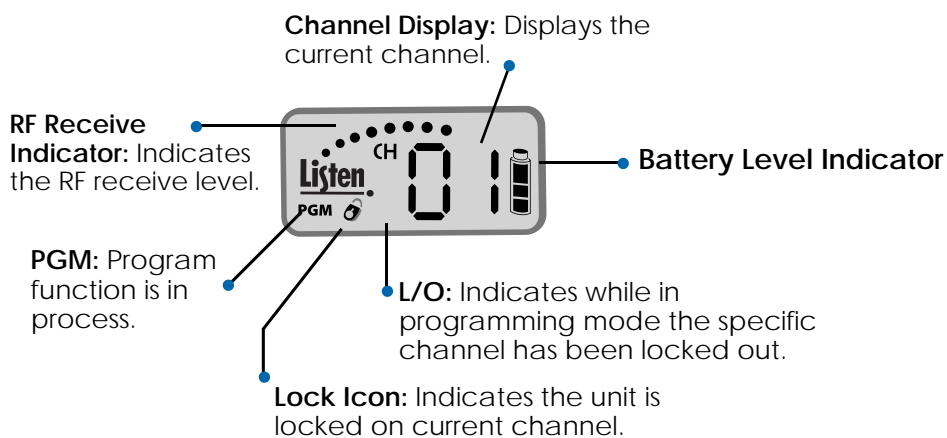
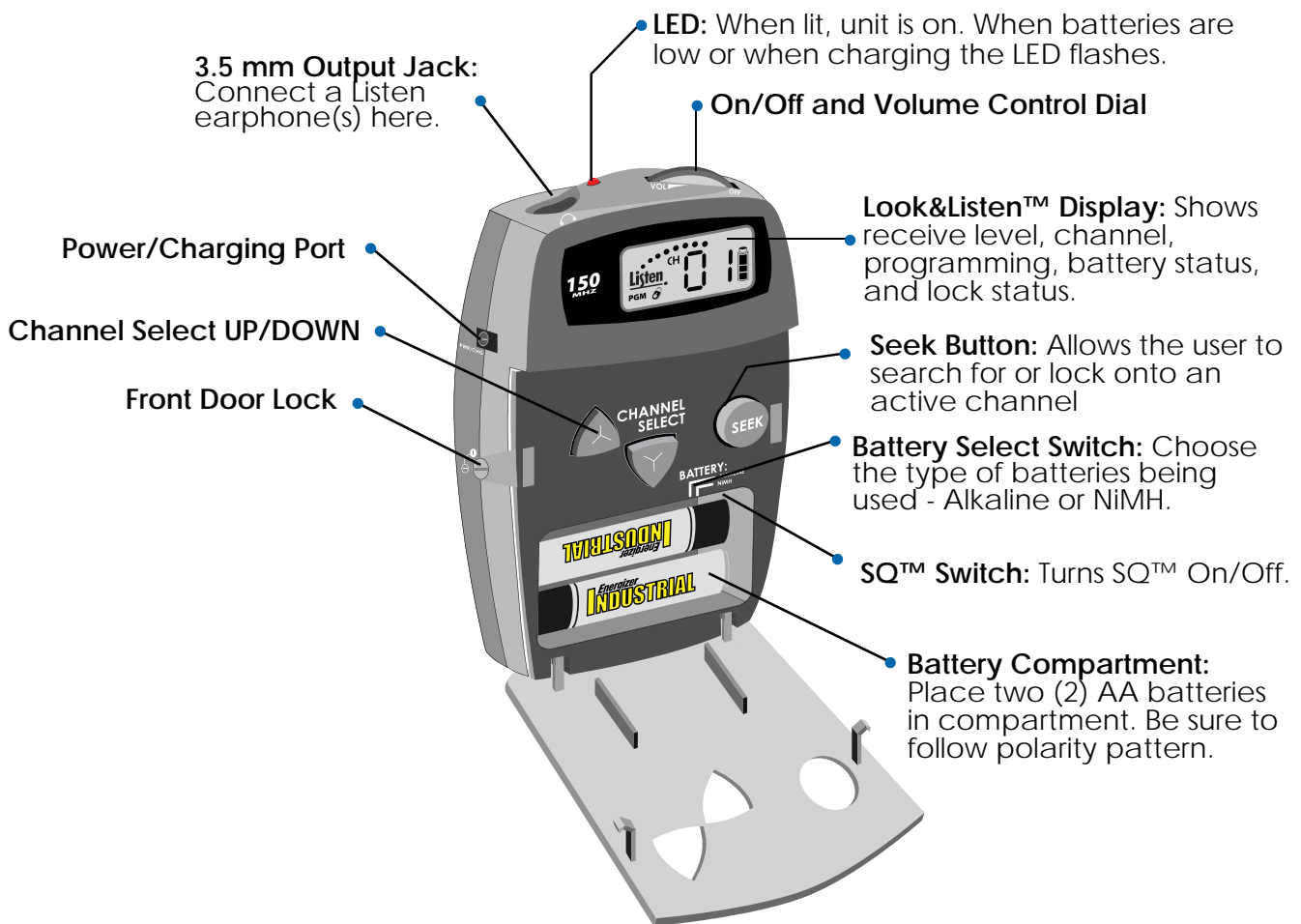

LR-500 Setup Instructions

1 Remove the product

Remove outer packaging and plastic cover. Inspect for physical damage. If damage is apparent, please contact Listen Technologies Corporation technical support for assistance.

2 Open the front access door

If locked, use a pocketknife or small screwdriver to unlock the door locks on both sides of the unit. To unlock the door, rotate the lock 1/4 turn counterclockwise.

Grip the two tabs with your thumb and index finger and pull the door downward. Do NOT place batteries in the unit yet.

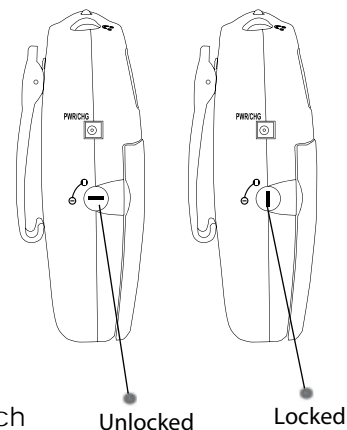

3 Select Battery Type

You have two choices: NiMH and Alkaline. The unit is shipped with the switch in the Alkaline position. Use a pen or small screwdriver to select the battery type.

CAUTION: If you are using any battery type other than rechargeable Nickel Metal Hydride (NiMH) batteries, make sure the BATTERY selection switch is in the alkaline position.

WARNING: Do not place the BATTERY switch in the NiMH position if you are not using Nickel Metal Hydride Batteries. The NiMH position will attempt to charge any batteries in the unit, even if they are not the proper type. Charging non-Nickel Metal Hydride (NiMH) batteries will result in physical harm, destruction of property and/or fire.

4 Set SQ switch

The SQ switch is inside the battery compartment next to the Battery Select switch. The unit is shipped with SQ in the ON position. To turn it off, use a small screwdriver or pen to slide the switch to the OFF position (to the right). See page 33 for more information on SQ.

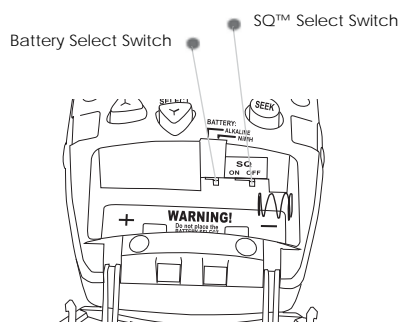

5 Place Batteries in Unit

Place two AA batteries in the compartment, making note of the battery polarity shown in the battery compartment, and again verifying that the BATTERY SELECT switch is in the correct position for the batteries you are using. (ALK should be selected for all battery types other than NiMH).

NOTE: Listen provides industrial strength AA alkaline batteries (part number LA-361) and high performance AA Nickel Metal Hydride batteries (part number LA-362). These may be purchased from your Listen dealer.

LR-500 Setup Instructions

- 6 Connect an Earphone or Headset**
Your headset or earphone will connect to the jack on the top of the unit. Either mono or stereo connectors may be used with a Listen receiver. Make certain you push the plug all the way into the jack.
- 7 Turn the Unit On**
Receivers are turned on by rotating the volume dial counterclockwise. The red LED on top of the unit should activate and the LCD display should illuminate. If they do not, make sure you have installed the batteries correctly and that you are using fully charged batteries.
- 8 Select Channel(s)**
See page 35 for complete channel selection information.
- 9 Set Squelch**
See page 14 for squelch and programming information.
- 10 Program Channels**
see page 13.

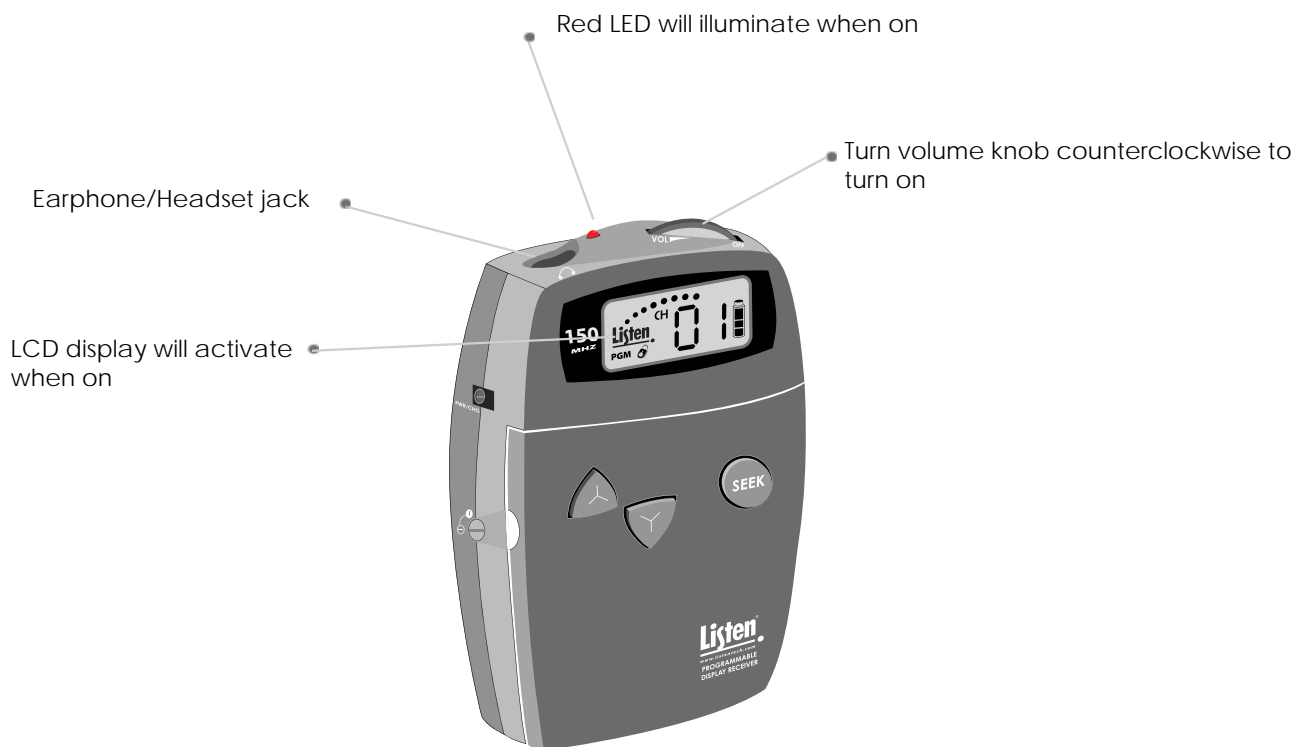

LR-500 Operation Instructions

1 **Make Sure the Unit is On**

Rotate the volume knob counterclockwise with an earphone or headset connected to the unit. Listen receivers use the cable of the earphone or headset as a receiving antenna.

Be careful when turning the unit on - if you turn the knob too far you might get too much volume in your earphone!

2 **Select a Channel**

Select the channel to match the transmission channel by pressing the UP and DOWN buttons on the receiver. Listen recommends the use of wide band channels.

150 MHz:

150 MHz receivers operate on 6 wide band channels and 26 narrow band channels. Channels 1-6 are Wideband & channels 7-32 are Narrowband.

Refer to the Frequency Compatibility Table (page 35) for specific frequencies and compatibility with other manufacturers.

3 **Test the audio**

If a transmitter is broadcasting on that channel, you will be able to hear the audio. If the signal is too weak, the audio will be muted (squelched).

4 **Find an audio transmission using SEEK**

Another way to find a channel on the LR-500 is to use the SEEK button. When you do this, the Listen receiver looks for the next active channel. Sometimes the unit will mistake interference for a real broadcast signal. If you get interference, press the SEEK button again. The unit may stop on a channel that is close to the actual broadcast channel, in which case the channel will sound noisy or distorted. Simply press SEEK again until you find the clearest operating channel.

5 **Adjust the volume control**

Use the control dial on the top of the unit to adjust the volume to a comfortable level.

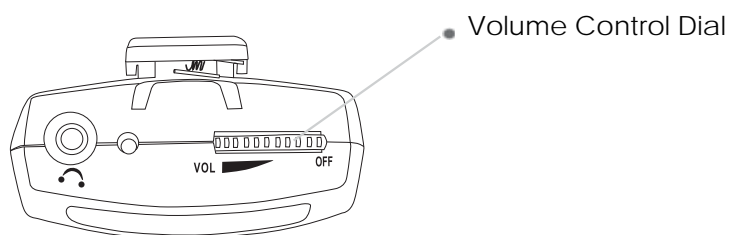

LR-500 Operation Instructions

6

To Lock into Only One Channel

Press and hold the SEEK button for 5 seconds to lock a receiver onto the currently tuned channel. Press and hold the button again to unlock. When locked the LED on top of the unit will flash when you press the SEEK button.

Is the Channel Locked on My Receiver?

On the LR-500, when the channel is locked, the padlock icon will appear on the display. If the unit is locked, the red LED on the top of the unit will flash when you press the SEEK button.

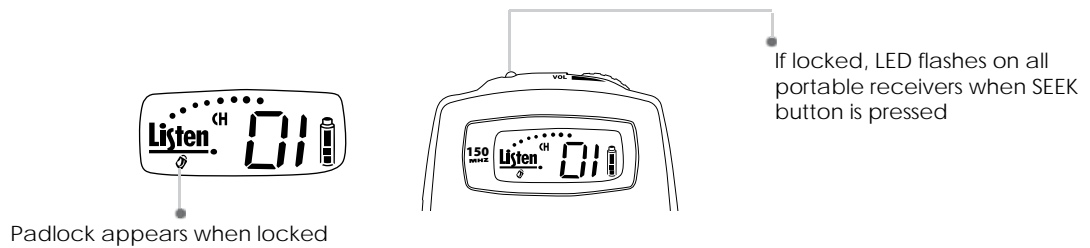

LR-500 Programming Instructions

The LR-500 Display Receiver has some special features not available in the other receivers: you may lock out unwanted channels, and you can adjust the squelch in the unit.

Locking Out Unwanted Channels

For applications where users are required to select a channel (such as language interpretation or classrooms), and you don't want them to have to go through all 32 available channels to find the appropriate channel, you can lock out all channels except the ones you are using in your facility.



UP and DOWN buttons on front of LR-500

1 Enter the PROGRAM mode

Press the UP and DOWN buttons simultaneously for 5 seconds, until the PGM symbol appears in the display.



2 Use the UP and DOWN keys to select channels

As channels are displayed on the unit, those channels that are locked out from user access will be indicated by the L/O (Locked Out) symbol. When a channel is locked out, the receiver will skip over that channel when a user is tuning the receiver.



3 Press the SEEK button to toggle channels between locked out and non-locked out modes

Exiting PROGRAM mode

To exit the PROGRAM mode, let the receiver sit idle (don't press any buttons) for 5 seconds. The receiver will automatically return to normal operation. If you haven't finished programming the unit and it automatically exits, press and hold the UP & DOWN buttons simultaneously for 5 seconds to re-enter the PROGRAM mode.

Squelch

The purpose of squelch is to mute the audio output of your receiver when the signal from the transmitter is turned off or is too weak to be received. Without squelch you would hear radio noise in your earphone. The squelch on your receiver can be adjusted so that it will mute the audio on different RF signal strengths. This is useful as follows:

- To ensure that users don't hear transmissions from other transmitters, set the squelch setting to the highest level that doesn't squelch the receiver.
- If the receiver is going to be close to the transmitter (i.e. in a classroom), setting the squelch setting high so that when the transmitter is turned off it immediately squelches and ignores transmitters in other rooms.
- If you are in an area that has a lot of interference, you may want to set the squelch setting to a high setting to ensure the interference is not picked by the receiver.
- If you need the maximum amount of range, you may want to consider setting the squelch setting to a low level (0, 1 or 2).

CAUTION: When setting the squelch level low the reliability of squelch function is comprised. This will cause radio noise to be heard in the earphone and there is a possibility of hearing damage.

Squelch Programming Instructions

Squelch Programming

To enter Squelch programming mode

- Turn the unit off
- Press and hold the seek button; while still holding seek turn the ON/OFF dial to turn the unit on.
- Release the seek button when the Listen name disappears and a two digit display is seen.

To adjust the Squelch level

- Use the Channel UP and DOWN buttons to raise or lower the squelch sensitivity settings.
- Lower numbers mean that a less powerful and possibly noisy signal will be heard, but you can have a longer range.
- Higher numbers mean that a more powerful signal with no noise will be heard, but you may have a shorter range.
- Once the desired squelch setting is found, press "seek" to exit the squelch programming mode.

Squelch setting 00 is no squelch; this effectively disables Squelching capabilities of the receiver. Squelch setting 20 is maximum squelch sensitivity; you must have a very strong and stable RF signal for the unit to not engage the squelch feature.

Adjusting the squelch setting will keep your LR-500 receiver from picking up noise when the transmitter is not transmitting, or when you lose the signal by being out of range or if encountering interference.

Note: For squelch settings 1-3, the squelch function is slow which allows for maximum transmission range. For squelch settings 4-20 the squelch function is fast to ensure little radio noise is heard during the squelch function.

(The Listen SQ™ feature is not squelch, please refer to page 33 for information on Listen SQ™).

LR-500 Charging Batteries

The LR-500 and all Listen receivers are unique because they have SmartCharge™ chargers built in. When any of these units are connected to an LA-208 wall transformer or dropped into a Listen charging case, NiMH batteries will be charged.

1 To charge the batteries using the LA-208 wall transformer, plug the transformer into the jack marked "PWR/CHG" on the side of the unit. The unit can be operated while the batteries are charging.

2 To charge the batteries using a drop-in charger, simply place the unit into a slot in the charger and connect the charger to power. Make sure the unit is fully seated in its slot.

SmartCharge™ uses a pulse charging, which greatly extends the life of Nickel Metal Hydride (NiMH) batteries. The entire charging process takes 13 hours. Listen recommends that you allow the charger to complete its full cycle every time for maximum battery life.

NOTE: In order to charge NiMH batteries, the BATTERY SELECT switch in your Listen product must be set to the NiMH setting. Use a pen or small screwdriver to move the switch (located in the battery compartment) to the proper position.

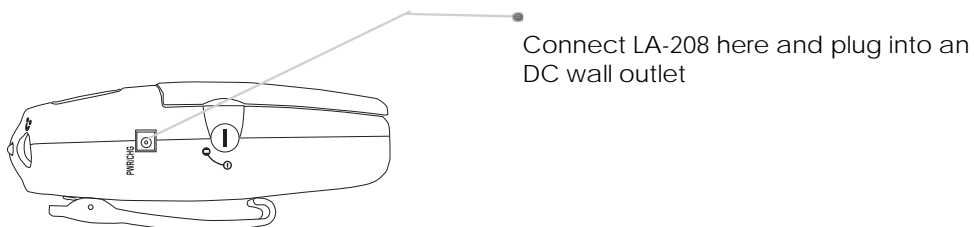

IMPORTANT: DO NOT ATTEMPT TO CHARGE ANY TYPE OF BATTERY OTHER THAN NiMH (NICKEL METAL HYDRIDE) with your Listen equipment. Alkaline batteries may explode when connected to a charger. Other risks of charging non-NiMH batteries include destruction of property or fire.

During the charge cycle, the red LED on top of the Listen product will flash slowly. When charging is completed, the LED will turn off. It is not necessary to unplug the charger; however, if you unplug the unit from the charger and then plug it back in, it will begin the 13-hour charge cycle over again.

When not using the LR-500, it is recommended to leave the unit on the charger. The charger provides a "maintenance" charge that keeps the battery at 100%. If the unit is not on the charger, the battery will lose up to 20% of its charge per month.

NOTE: Listen provides high performance constant current NiMH (Nickel Metal Hydride) batteries. These may be purchased from your Listen dealer (ask for part number LA-362).

LR-500 Wall Transformer Operation

The LR-500 will operate normally when connected to a wall transformer. Use Listen part number LA-208, available from any Listen dealer. Connect the wall transformer to the jack on the side of the LR-500 marked "PWR/CHG" and plug the wall transformer into a grounded AC outlet.

You do not need to have batteries installed in the LR-500 to operate it with a wall transformer.

NOTE: If batteries are in the unit ensure that the battery selection switch is set properly as shown on page 9. Please review the information on page 15 for important information regarding battery type and charging.

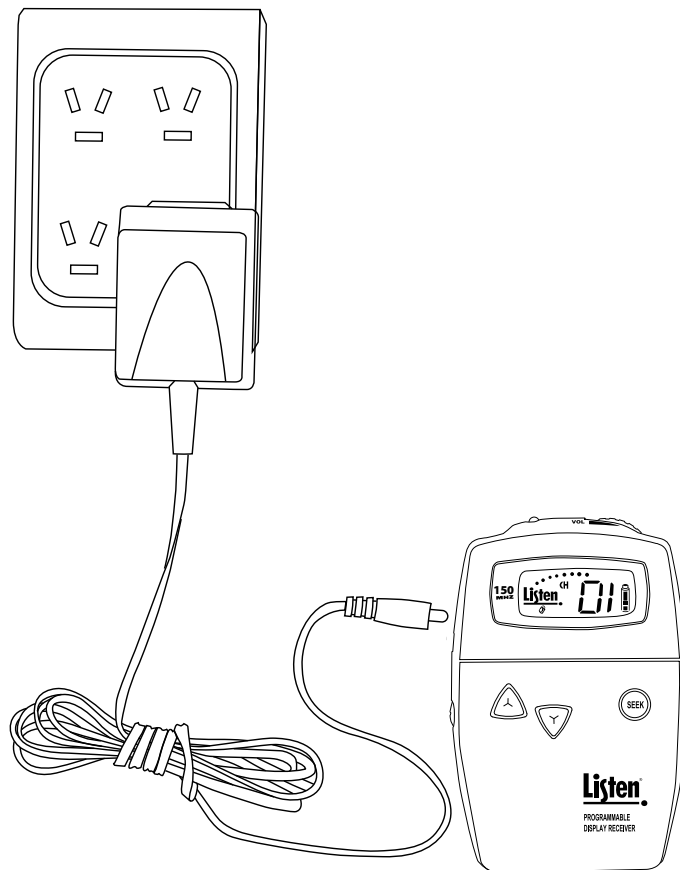

The LA-208 wall transformer plugs into the side of your portable transmitter or receiver



LR-400-Portable Portable Display FM Receiver

Don't miss a single sound.

LR-400 Table of Contents

Package Contents	22
Architectural Specifications	23
Specifications	23
Quick Reference	24
Setup Instructions	25
Operation Instructions	27
Squelch Information	29
Squelch Programming	29
Charging Batteries	30
Wall Transformer Operation	31

LR-400 Package Contents

LR-400 Contents

- LR-400 Portable Display FM Receiver (150 MHz)

Listen Part Number

- LR-400-150 (150 MHz)



LR-400 Specifications

Architectural Specifications

The FM receiver shall be capable of receiving on 32 channels. The receiver shall have a SNR of 80 dB or greater. The receiver shall be capable of seeking for open channels and locked on an active channel. The device shall have a squelch. The unit shall have an audio frequency response of 50 Hz to 15 kHz (± 3 dB). The device shall incorporate a stereo headset jack that allows the user to plug in either a mono or stereo headset and listen to audio normally. The device shall incorporate an LCD display. The receiver shall incorporate automatic battery charging circuitry. The device shall be able to use of two (2) alkaline or NiMH batteries. The Listen LR-400-150 is specified.

Specifications*		
Audio	RF Frequency Range	150.8000 MHz - 152.3500 MHz
	Number of Channels	6 wide band, 26 narrow band
	Sensitivity	.6uV typical, 1 uV maximum for 12 dB sinad
	Frequency Accuracy	$\pm .005\%$ stability 32 to 122 °F (0 to 50 °C)
	Antenna	Uses earphone cable
	Squelch	Programmable in 20 steps, automatic on loss of RF signal
	System Frequency Response	50 Hz - 15 kHz (± 3 dB)
	System Signal to Noise Ratio	SQ enabled 80 dB, SQ disabled 60 dB
	System Distortion	<2% total harmonic distortion (THD) at 80% deviation
	Output	3.5 mm (0.14 in.) connectors, unbalanced, 0 dBu nominal output level, 16 mW maximum, impedance 32 ohm
Controls & Indicators	User Controls	Channel up/down, SEEK, volume
	Set-up Controls (Battery Compartment)	Alkaline/NiMH batteries, SQ enable/disable
	Programming	Channel lock, squelch
	LED	Red, illuminated when unit is on, flashes when batteries are low or to indicate charging, flashes when locked and SEEK is pushed
	Display	Channel designation, battery level, battery charging, RF signal strength and channel lock
Power	Battery Type	Two (2) AA batteries, alkaline or NiMH
	Battery Life (Listen Batteries)	30 hours alkaline (LA-361), 15 hours NiMH rechargeable (LA-362)
	Battery Charging (NiMH only)	Fully automatic, 13 hours
	Power Supply	I/P 120 VAC; O/P 7.5 VDC 250 mA, drop in contact points for use with charging cases, power supply not included (LA-208)
	Power Supply Connector	0.09 in. (2.3 mm) OD by 0.7 mm ID, barrel type connector 7.5 VDC, center positive <250 mA, drop in contact points for use with Listen charging cases
	Power Supply Compliance	RoHS, WEEE, UL, PSE, CE, CUL, TUV, CB
Physical	Dimensions (H x W x D)	4.25 x 2.75 x 1.50 in. (10.8 x 7.0 x 3.8 cm)
	Color	Dark Grey with white silk screening
	Unit Weight	3.9 oz (111 g)
	Unit Weight with batteries	5.8 oz (164 g)
	Shipping Weight	6.1 oz (173 g)
	Door	Manually lockable (on sides), SEEK/channel select behind the door
Environmental	Temperature - Operation	14 to 104 °F (-10 to 40 °C)
	Temperature - Storage	(-)4 to 122 °F (-20 to 50 °C)
	Humidity	0 to 95% relative humidity, non-condensing

*Specifications are subject to change without notification

LR-400 Quick Reference

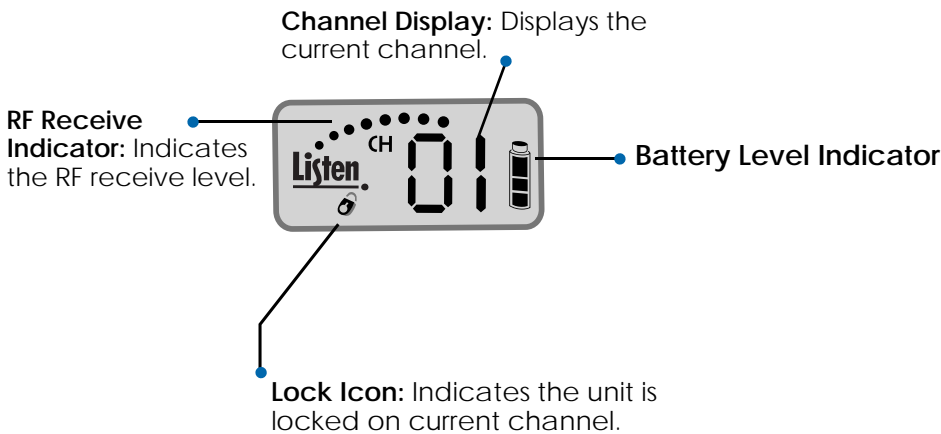
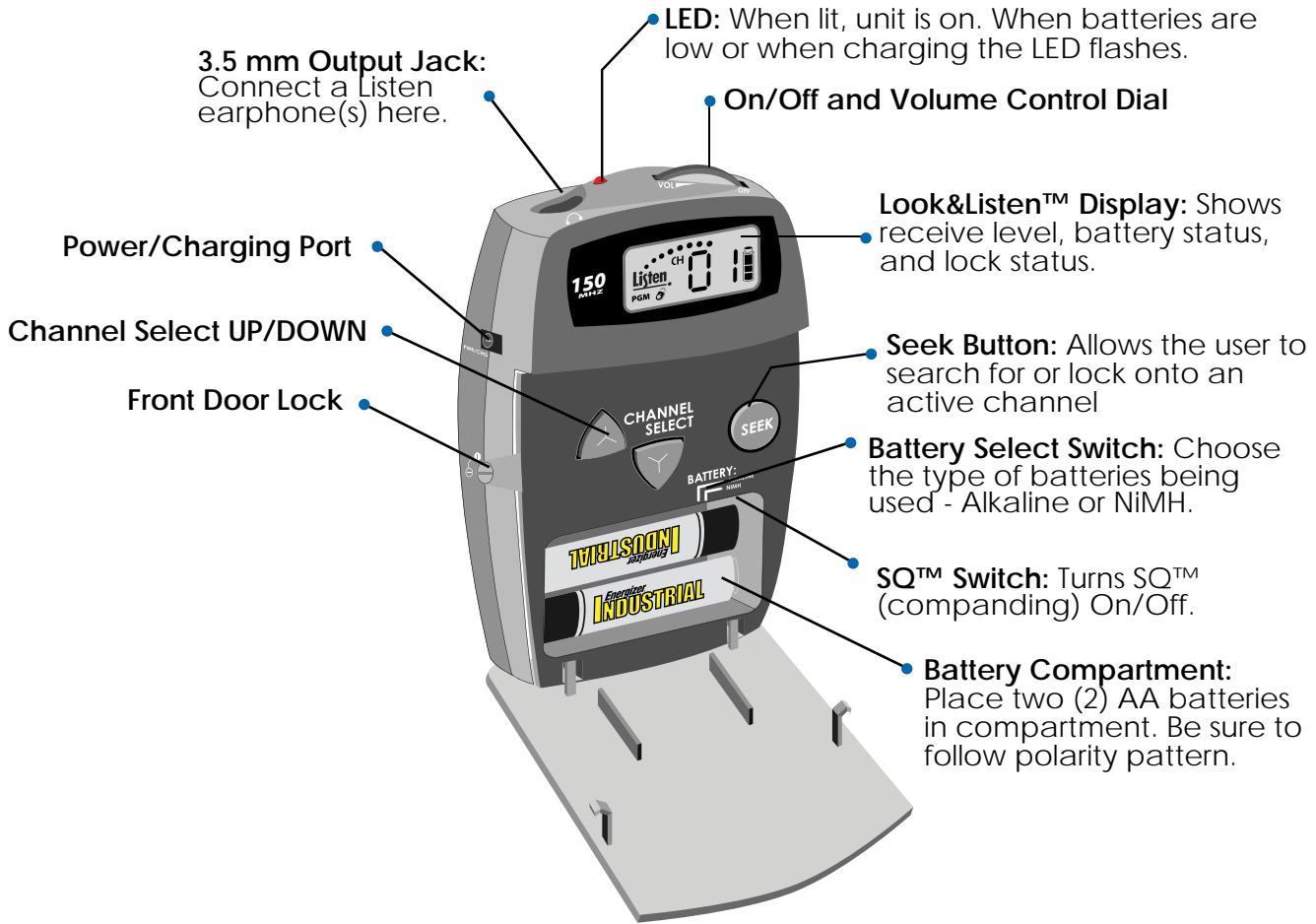

LR-400 Setup Instructions

1 Remove the product

Remove outer packaging and plastic cover. Inspect for physical damage. If damage is apparent, please contact Listen Technologies Corporation technical support for assistance.

2 Open the front access door

If locked, use a pocketknife or small screwdriver to unlock the door locks on both sides of the unit. To unlock the door, rotate the lock 1/4 turn counterclockwise.

Grip the two tabs with your thumb and index finger and pull the door downward. Do NOT place batteries in the unit yet.

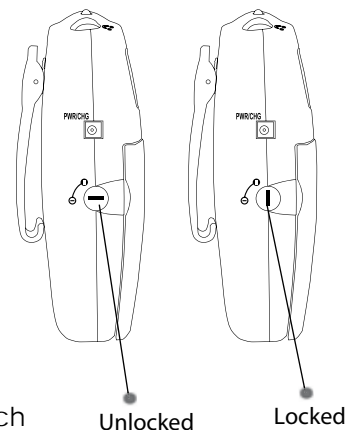

3 Select Battery Type

You have two choices: NiMH and Alkaline. The unit is shipped with the switch in the Alkaline position. Use a pen or small screwdriver to select the battery type.

CAUTION: If you are using any battery type other than rechargeable Nickel Metal Hydride (NiMH) batteries, make sure the BATTERY selection switch is in the alkaline position.

WARNING: Do not place the BATTERY switch in the NiMH position if you are not using Nickel Metal Hydride Batteries. The NiMH position will attempt to charge any batteries in the unit, even if they are not the proper type. Charging non-Nickel Metal Hydride (NiMH) batteries will result in physical harm, destruction of property and/or fire.

4 Set SQ switch

The SQ switch is inside the battery compartment next to the Battery Select switch. The unit is shipped with SQ in the ON position. To turn it off, use a small screwdriver or pen to slide the switch to the OFF position (to the right). See page 33 for more information on SQ.

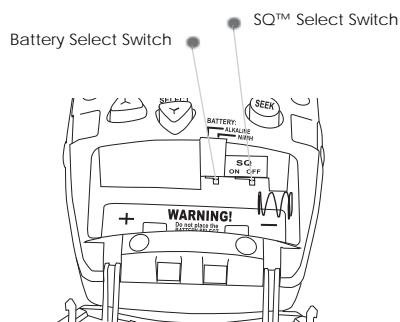

5 Place Batteries in Unit

Place two AA batteries in the compartment, making note of the battery polarity shown in the battery compartment, and again verifying that the BATTERY SELECT switch is in the correct position for the batteries you are using. (ALK should be selected for all battery types other than NiMH).

NOTE: Listen provides industrial strength AA alkaline batteries (part number LA-361) and high performance AA Nickel Metal Hydride batteries (part number LA-362). These may be purchased from your Listen dealer.

LR-400 Setup Instructions

6 Connect an Earphone or Headset
Your headset or earphone will connect to the jack on the top of the unit. Either mono or stereo connectors may be used with a Listen receiver. Make certain you push the plug all the way into the jack.

7 Turn the Unit On
Receivers are turned on by rotating the volume dial counterclockwise. The red LED on top of the unit should activate and the LCD display should illuminate. If they do not, make sure you have installed the batteries correctly and that you are using fully charged batteries.

8 Select Channel(s)
See page 33 for complete channel selection information.

9 Set Squelch
See page 29 for squelch and programming information.



LR-400 Operation Instructions

1 **Make Sure the Unit is On**

Rotate the volume knob counterclockwise with an earphone or headset connected to the unit. Listen receivers use the cable of the earphone or headset as a receiving antenna.

Be careful when turning the unit on - if you turn the knob too far you might get too much volume in your earphone!

2 **Select a Channel**

Select the channel to match the transmission channel by pressing the UP and DOWN buttons on the receiver. Listen recommends the use of wide band channels.

150 MHz:

150 MHz receivers operate on 6 wide band channels and 26 narrow band channels. Channels 1-6 are Wideband & channels 7-32 are Narrowband.

Refer to the Frequency Compatibility Table (page 35) for specific frequencies and compatibility with other manufacturers.

3 **Test the audio**

If a transmitter is broadcasting on that channel, you will be able to hear the audio. If the signal is too weak, the audio will be muted (squelched).

4 **Find an audio transmission using SEEK**

Another way to find a channel on the LR-400 is to use the SEEK button. When you do this, the Listen receiver looks for the next active channel. Sometimes the unit will mistake interference for a real broadcast signal. If you get interference, press the SEEK button again. The unit may stop on a channel that is close to the actual broadcast channel, in which case the channel will sound noisy or distorted. Simply press SEEK again until you find the clearest operating channel.

5 **Adjust the volume control**

Use the control dial on the top of the unit to adjust the volume to a comfortable level.

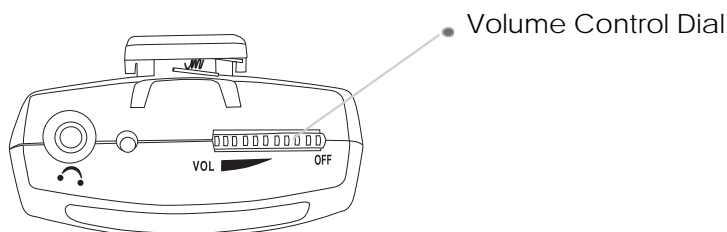

6

To Lock into Only One Channel

Press and hold the SEEK button for 5 seconds to lock a receiver onto the currently tuned channel. Press and hold the button again to unlock. When locked the LED on top of the unit will flash when you press the SEEK button.

Is the Channel Locked on My Receiver?

On the LR-400, when the channel is locked, the padlock icon will appear on the display. If the unit is locked, the red LED on the top of the unit will flash when you press the SEEK button.



Padlock appears when locked

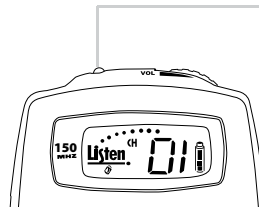

If locked, LED flashes on all portable receivers when SEEK button is pressed

LR-400 Squelch

Squelch

The purpose of squelch is to mute the audio output of your receiver when the signal from the transmitter is turned off or is too weak to be received. Without squelch you would hear radio noise in your earphone. The squelch on your receiver can be adjusted so that it will mute the audio on different RF signal strengths. This is useful as follows:

- To ensure that users don't hear transmissions from other transmitters, set the squelch setting to the highest level that doesn't squelch the receiver.
- If the receiver is going to be close to the transmitter (i.e. in a classroom), setting the squelch setting high so that when the transmitter is turned off it immediately squelches and ignores transmitters in other rooms.
- If you are in an area that has a lot of inference, you may want to set the squelch setting to a high setting to ensure the interference is not picked by the receiver.
- If you need the maximum amount of range, you may want to consider setting the squelch setting to a low level (0, 1 or 2).

CAUTION: When setting the squelch level low the reliability of squelch function is comprised. This will cause radio noise to be heard in the earphone and there is a possibility of hearing damage.

Squelch Programming Instructions

Squelch Programming

To enter Squelch programming mode

- Turn the unit off
- Press and hold the seek button; while still holding seek turn the ON/OFF dial to turn the unit on.
- Release the seek button when the Listen name disappears and a two digit display is seen.

To adjust the Squelch level

- Use the Channel UP and DOWN buttons to raise or lower the squelch sensitivity settings.
- Lower numbers mean that a less powerful and possibly noisy signal will be heard, but you can have a longer range.
- Higher numbers mean that a more powerful signal with no noise will be heard, but you may have a shorter range.
- Once the desired squelch setting is found, press "seek" to exit the squelch programming mode.

Squelch setting 00 is no squelch; this effectively disables Squelching capabilities of the receiver. Squelch setting 20 is maximum squelch sensitivity; you must have a very strong and stable RF signal for the unit to not engage the squelch feature.

Adjusting the squelch setting will keep your LR-400 receiver from picking up noise when the transmitter is not transmitting, or when you lose the signal by being out of range or if encountering interference.

Note: For squelch settings 1-3, the squelch function is slow which allows for maximum transmission range. For squelch settings 4-20 the squelch function is fast to ensure little radio noise is heard during the squelch function.

(The Listen SQ™ feature is not squelch, please refer to page 33 for information on Listen SQ™).

LR-400 Charging Batteries

The LR-400 and all Listen receivers are unique because they have SmartCharge™ chargers built in. When any of these units are connected to an LA-208 wall transformer or dropped into a Listen charging case, NiMH batteries will be charged.

1 To charge the batteries using the LA-208 wall transformer, plug the transformer into the jack marked “PWR/CHG” on the side of the unit. The unit can be operated while the batteries are charging.

2 To charge the batteries using a drop-in charger, simply place the unit into a slot in the charger and connect the charger to power. Make sure the unit is fully seated in its slot.

SmartCharge™ uses a pulse charging, which greatly extends the life of Nickel Metal Hydride (NiMH) batteries. The entire charging process takes 13 hours. Listen recommends that you allow the charger to complete its full cycle every time for maximum battery life.

NOTE: In order to charge NiMH batteries, the BATTERY SELECT switch in your Listen product must be set to the NiMH setting. Use a pen or small screwdriver to move the switch (located in the battery compartment) to the proper position.

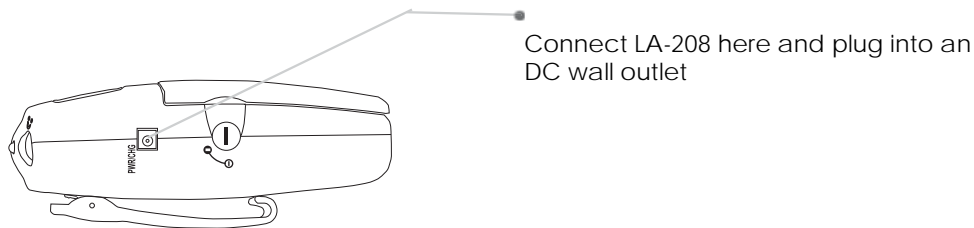

IMPORTANT: DO NOT ATTEMPT TO CHARGE ANY TYPE OF BATTERY OTHER THAN NiMH (NICKEL METAL HYDRIDE) with your Listen equipment. Alkaline batteries may explode when connected to a charger. Other risks of charging non-NiMH batteries include destruction of property or fire.

During the charge cycle, the red LED on top of the Listen product will flash slowly. When charging is completed, the LED will turn off. It is not necessary to unplug the charger; however, if you unplug the unit from the charger and then plug it back in, it will begin the 13-hour charge cycle over again.

When not using the LR-400, it is recommended to leave the unit on the charger. The charger provides a “maintenance” charge that keeps the battery at 100%. If the unit is not on the charger, the battery will lose up to 20% of its charge per month.

NOTE: Listen provides high performance constant current NiMH (Nickel Metal Hydride) batteries. These may be purchased from your Listen dealer (ask for part number LA-362).

LR-400 Wall Transformer Operation

The LR-400 will operate normally when connected to a wall transformer. Use Listen part number LA-208, available from any Listen dealer. Connect the wall transformer to the jack on the side of the LR-400 marked "PWR/CHG" and plug the wall transformer into a grounded AC outlet.

You do not need to have batteries installed in the LR-400 to operate it with a wall transformer.

NOTE: If batteries are in the unit ensure that the battery selection switch is set properly as shown on page 25. Please review the information on page 30 for important information regarding battery type and charging.

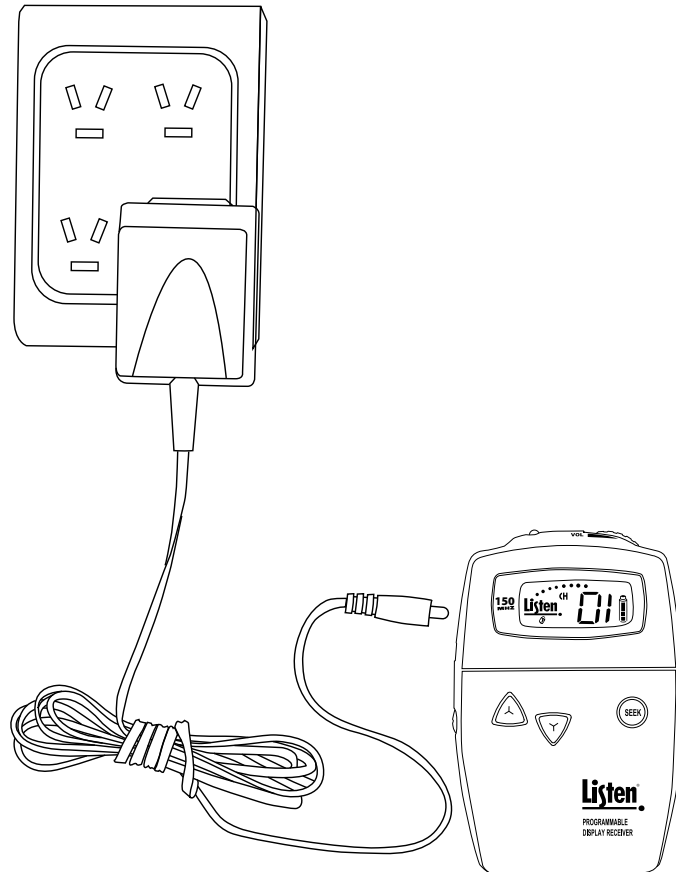

The LA-208 wall transformer plugs into the side of your portable transmitter or receiver

Channel Selection

It is important to choose channels that are free from interference to achieve proper operation of your Listen equipment. This process is trial and error. Before turning on the transmitter, listen to the wide band channels on the receivers (channels 1-6). Listen to the audio through the headphone or via the speaker and choose a channel with the least amount of interference. Unless you are interfacing with an existing narrowband transmission system, always use a wide band channel.

If you are using multiple channels follow this process:

1. **Same Space:** If you are using multiple transmitters in the same space, the most number of channels that will work simultaneously is six at 150 MHz. With all of the transmitters off, listen for interference on all the wide band channels via the headphone jack on a Listen receiver. Using the frequency chart on page 35, eliminate any channels that have noticeable interference. Now choose the channels with the widest channel spacing. It is recommended that adjacent channels be spaced at least 300kHz.
2. **Distributed Spacing:** If you are using transmitters that are spread out over space, you can achieve more simultaneous broadcast channels. However, it is critical that your receiver(s) be located as close to its transmitter as possible. You can use adjacent channels (see frequency chart on page 35) in this case as long as the adjacent channel transmitter is at least 50% further away from the receiver as its transmitter.

It is highly recommended that after channel selection has been achieved, you lock the channel so that it cannot be changed by the user. To accomplish LOCK on the LT-800, press the "UP" button for 3 seconds. Repeat the process to unlock.

Wide Band Recommendation

Listen recommends that you always use a wide band channel unless you need to be compatible with existing narrow band receivers from other manufacturers. Wide band channels have lower noise than their narrow band counterparts.

150 MHz

The LT-800-150 MHz operates on 6 wide band channels and 26 narrow band channels.

- 1 - 6 = Wide Band Channels
- 7 - 32 = Narrow Band Channels

People are accustomed to listening to low noise, high fidelity audio (delivered via CD, DVD, etc.). FM radio systems, such as those made by Listen, have more inherent noise compared to most sound systems. To minimize noise, Listen uses a noise reduction technology called ListenSQ™. Both the transmitter and receiver must have the SQ feature enabled to achieve the desired results. SQ is available on new Listen systems, including the system you received in this shipment. If you are planning to use this product with older Listen systems that do not have Listen SQ, or equipment not manufactured by Listen, you must disable Listen SQ.

Your Listen LT-800 has been shipped to you with the SQ feature enabled. You may need to disable the SQ function for one or more of the following reasons:

- 1 You are using your new Listen LT-800 with older version Listen receivers that do not have the SQ function.
- 2 You are using your new Listen LT-800 with equipment supplied by other manufacturers (Listen is the only manufacturer using SQ Technology).
- 3 You expect that end users will bring and use their own receivers that don't have the SQ function.

NOTE: See page 8 to enable or disable SQ (Super Quiet).

Process Mode

Process mode is used for Audio Gain Control (AGC). With the process mode enabled, the LT-800 will automatically adjust for inconsistent signal input levels by raising or lowering the signal level accordingly to provide a consistent sound output level. This feature should be used in applications where a consistent sound level is important and the input levels vary substantially. Typically you would not want to engage the Process Mode when a speaker's emphasis is critical to the message they are conveying.

SQ Summary

- SQ is NOT squelch
- SQ improves noise performance by at least 20 dB
- SQ is NOT compatible with older version Listen products
- SQ is NOT compatible with other manufacturers' products
- To work properly, SQ must be enabled for both the transmitter and receivers
- SQ can be disabled to permit operation with older Listen products or other manufacturers' products

RF Reception Maximization Strategies

For proper and dependable operation, Listen receivers need to receive a strong and consistent signal from the originating transmitter. Note that on portable receivers the headset wire is the receiving antenna. The following strategies should be used maximize to this signal:

- 1 When designing and installing your system, keep in mind that the location of both the transmitting and receiving antennas is critical to maximize broadcast range.
- 2 Eliminate or minimize obstructions between the transmitting and receiving antenna.
- 3 Minimize the distance between the transmitting and receiving antennas.
- 4 Move transmitting and receiving antennas away from metal or conductive objects.
- 5 Place the transmitting antenna as high as possible.
- 6 Orient both transmitting and receiving antennas vertically.
- 7 Position the RF Power switch on the back of the LT-800 to full RF Power, unless lower power is acceptable (see page 8).
- 8 Keep coaxial cable from transmitter to antenna as short as possible.

CAUTION: *When installing antennas, ensure the antenna is clear of power lines.*

Coaxial Cable

The antenna for the LT-800 can be mounted directly on the unit if desired. However, you may find that the unit will provide better performance when the antenna is located elsewhere. If you plan to mount the antenna in a different location other than the top of the unit, you must use cable and connectors rated at 50 ohms. Although cable used for cable TV installations looks similar to this cable, it will not work with your Listen system.

If you need to run cable over a length greater than 75 feet for 150 MHz applications or to maximize broadcast range, Listen recommends that you use RG-8 cable rather than RG-58. RG-8 is a lower loss cable, meaning that more of your signal will reach the antenna.

Long cable runs can result in signal degradation due to the "loss" characteristics of the cable. When using RG-58 with a 150 MHz transmitter, there is an average* loss of 6 dB per 100 feet of cable (A 3 dB loss means half of your power has been lost.) However, it is better to suffer coaxial power loss than to try to shoot your signal through obstacles! Obstacles, especially metal, can create drop-outs or reflections of your signal that will result in poor listening conditions.

***NOTE:** *There are many varieties of 50 ohm, RG-58 and RG-8 cables. You may purchase a cable that is better or worse than this value. Please check with the cable vendor or manufacturer for exact specifications.*

150 MHz Compatibility Chart

Channel	Frequency
01	150.900
02	152.400
03	151.500
04	152.100
05	151.200
06	151.800
07	150.850
08	150.950
09	151.000
10	151.050
11	151.100
12	151.150
13	151.250
14	151.300
15	151.350
16	151.400
17	151.450
18	151.550
19	151.600
20	151.650
21	151.700
22	151.750
23	151.850
24	151.900
25	151.950
26	152.000
27	152.050
28	152.150
29	152.200
30	152.250
31	152.300
32	152.350

Troubleshooting

The receiver has no power.

Make sure the unit has either fully charged batteries or a Listen approved wall transformer connected. Make sure the VOLUME knob has been rotated to the ON position. If this does not work, try a different set of batteries. Make sure the batteries are installed properly.

There is no audio.

Make sure you have turned the volume control up. Make sure the earphone is plugged all the way into the jack on the top of the unit. Make sure the transmitter is broadcasting an audio source. Make sure you're tuned to the same channel as the transmitter. If the RF signal is too weak, the receiver will squelch and mute the audio source; move closer to the antenna or make sure the transmitter's output RF power switch is set on "FULL" (LT-800).

The audio is distorted.

Make sure you're receiving on the correct channel. Make sure the audio on the transmitter is not turned up too loud; this will cause distortion. Make sure the earphone connector is pushed all the way into the jack on top of the unit. Make sure the SQ™ switch on your transmitter and receivers is turned ON (or OFF, if some of your equipment is not SQ™ capable). Make sure you are not too close to the transmitting antenna. If you can't get farther away from the antenna, turn down the RF output power on the stationary (LT-800) transmitter.

There is interference.

Try different frequencies on the transmitter and receivers until you find a clear channel. Please contact Listen technical support for assistance (see page 38 for information).

I cannot pick up the signal on the receiver.

Check to make sure the receiver and the transmitter are on the same frequency and channel. Also make sure the receiver is in broadcast range of the transmitter.

I can pick up the signal on the receiver, but it sounds like it's not tuned in.

Check to make sure the transmitter and receiver are on exactly the same channel number/letter.

There is not sufficient range.

Make sure you are located as close as possible to the antenna of the transmitter. Try to place the antenna as high as possible and free from obstacles. You can also check the squelch setting; perhaps it is too sensitive. To change this setting, refer page 14 (LR-500) or to page 29 (LR-400).

Troubleshooting

Users keep changing channels.

You can prevent users from changing channels by locking in the channel selection. This is done by pressing and holding the SEEK button for 5 seconds. When the channel is locked, the padlock icon will appear on the LR-400 and LR-500 displays. The LED will also flash when the channel is locked and seek is pressed. In addition, you can lock the access doors to the units.

I cannot change channels when pressing the UP and DOWN buttons or the SEEK button.

The unit is locked. Press the SEEK button for 5 seconds to unlock.

When I change channels, only certain channels are accessible.

The unit has been programmed to tune to only certain channels (LR-500 only). You can change these channel lock-out selections by re-programming the unit (see page 13).

My batteries are not charging.

Make sure the battery switch is in the NiMH setting and that you are using NiMH (Nickel Metal Hydride) batteries. Make sure you are using only a Listen supplied charging unit or transformer. Never try to charge alkaline or NICAD batteries.

I want to run the unit from a wall transformer.

Simply plug a Listen approved transformer (LA-208) to the CHG/PWR connector on the side of the unit. Batteries do not need to be installed when operating the unit with a wall transformer; however, if you have NiMH batteries installed and the BATTERY select switch is set to NiMH, the batteries will charge while the unit is being used.

It's confusing for users to have 32 choices when switching between channels.

Use the programming feature (only available in the LR-500) to limit the number of channels accessible by users.

Warranty & Contacting Listen

Warranty

Listen Technologies Corporation (Listen) warrants its transmitters and receivers (LT-82, LT-700, LT-800, LR-42, LR-44, LR-400, LR-500) to be free from defects in workmanship and material under normal use and conditions for the useful lifetime of the product from date of purchase.

Listen warrants its Stationary IR Radiators (LA-140) to be free from defects in workmanship and material under normal use and conditions for three years from the date of purchase.

Listen warrants its Noise Canceling Microphone (LA-270) to be free from defects in workmanship and material under normal use and conditions for one year from date of purchase.

Listen warrants its Charging/Carrying Cases (LA-306, LA-311, LA-313, LA-317, LA-318, LA-319, LA-320, LA-321, LA-322, LA-323, LA-324, LA-325) to be free from defects in workmanship and material under normal use and conditions for one year from date of purchase.

All other products and accessories are warranted for 90 days from date of purchase.

This warranty is only available to the original end purchaser of the product and cannot be transferred. Warranty is only valid if warranty card has been returned within 90 days of purchase. This warranty is void if damage occurred because of misuse or if the product has been repaired or modified by anyone other than a factory authorized service technician. Warranty does not cover normal wear and tear on the product or any other physical damage unless the damage was the result of a manufacturing defect. Listen is not liable for consequential damages due to any failure of equipment to perform as intended. Listen shall bear no responsibility or obligation with respect to the manner of use of any equipment sold by it. Listen specifically disclaims and negates any warranty of merchantability or fitness of use of such equipment including, without limitation, any warranty that the use of such equipment for any purpose will comply with applicable laws and regulations. The terms of the warranty are governed by the laws of the state of Utah.

In the first ninety days after purchase, any defective product will be replaced with a new unit. After 90 days, Listen will, at its own discretion either repair or replace transmitters and receivers with a new unit or a unit of similar type and condition. Product that is not covered under warranty shall be repaired or replaced with a unit of similar type and condition based on a flat fee. Contact Listen for details.

This limited warranty, prices and the specifications of products are subject to change without notice.

Contacting Listen

If technical service is needed, please contact Listen. Pre-authorization is required before returning Listen products. If products were damaged in shipment, please contact the carrier, then contact Listen for replacement or repair requirements payable by the carrier.

Listen's corporate headquarters are located in Bluffdale, Utah U.S.A. and are open Monday through Friday, 8am to 5pm Mountain Time.

14912 Heritagecrest Way
Bluffdale, Utah 84065-4818
+1.801.233.8992
1.800.330.0891 North America
+1.801.233.8995 fax

support@listentech.com
www.listentech.com

Optional Accessories

Earphone Options



LA-164
Ear Speaker



LA-161
Single Ear Bud



LA-162
Stereo Ear Buds



LA-165
Stereo Headphones



LA-166
Neck Loop



LA-170
Behind-the-Head
Stereo Headphones

Connector Options



LA-265
Consumer
Camcorder Cable



LA-266
Professional
Camcorder Cable



LA-275
Sacrificial Cable

Optional Accessories

Accessories



- LA-311 16-Unit Portable Charging/Carrying Case
- LA-313 16-Unit Portable Carrying Case
- LA-317 4-Unit Portable Charging/Carrying Case
- LA-318 4-Unit Portable Carrying Case
- LA-320 Configurable Carrying Case
- LA-321 8-Unit Portable Charging/Carrying Case
- LA-322 8-Unit Portable Carrying Case
- LA-323 4-Unit Portable Charging/Carrying Case w/Removable Lid
- LA-324 8-Unit Portable Charging/Carrying Case w/Removable Lid
- LA-325 16-Unit Portable Charging/Carrying Case w/Removable Lid



LA-361
High Capacity AA Alkaline
Batteries (2)



LA-362
Rechargeable AA NiMH
Batteries (2)



Listen Technologies Corporation
14912 Heritagecrest Way
Bluffdale, Utah 84065-4818, U.S.A.
+1.801.233.8992
1.800.330.0891 North America
+1.801.233.8995 fax

www.listentech.com

© 2009 Listen Technologies Corporation® All Rights Reserved 09162009